

**Smart Temperature Compensation Attenuator DC~6GHz 50Ω 100mW 1~10dB N3~N10**
**Part No. Descriptions**

|        |           |                            |                              |                         |                                     |   |
|--------|-----------|----------------------------|------------------------------|-------------------------|-------------------------------------|---|
| ***    | **        | **                         | **                           | **                      | **                                  | * |
| Series | Frequency | Attenuation                | Temperature Coefficient Code | Metallization Options   | Termination Plating Options         |   |
|        |           |                            |                              |                         |                                     |   |
| STCA,  | 06        | (01 to 10)<br>1dB to 10 dB | N3 to N10                    | Planar(no code), W1, W3 | (no code)=lead free or (S)=Lead(Pb) |   |

| Part No.   | Frequency Range (GHz) | Attenuation (dB) | Temperature Coefficient Code | Temperature Coefficient of Attenuation (dB/dB/°C) | Max. VSWR (:1) @1GHz@25°C | Max. Input Power (mW) | Attenuation Accuracy (dB) |
|------------|-----------------------|------------------|------------------------------|---|---------------------------|-----------------------|---------------------------|
| STCA0601N* | DC-6                  | 1                | N3~N9                        | -0.003~ -0.009                                    | 1.20                      | 100                   | ±0.5                      |
| STCA0602N* | DC-6                  | 2                | N3~N10                       | -0.003~ -0.010                                    | 1.20                      | 100                   | ±0.5                      |
| STCA0603N* | DC-6                  | 3                | N3~N10                       | -0.003~ -0.010                                    | 1.20                      | 100                   | ±0.5                      |
| STCA0604N* | DC-6                  | 4                | N3~N10                       | -0.003~ -0.010                                    | 1.20                      | 100                   | ±0.5                      |
| STCA0605N* | DC-6                  | 5                | N3~N10                       | -0.003~ -0.010                                    | 1.20                      | 100                   | ±0.5                      |
| STCA0606N* | DC-6                  | 6                | N3~N10                       | -0.003~ -0.010                                    | 1.20                      | 100                   | ±0.5                      |
| STCA0607N* | DC-6                  | 7                | N3~N10                       | -0.003~ -0.010                                    | 1.20                      | 100                   | ±0.5                      |
| STCA0608N* | DC-6                  | 8                | N3~N10                       | -0.003~ -0.010                                    | 1.20                      | 100                   | ±0.5                      |
| STCA0609N* | DC-6                  | 9                | N3~N10                       | -0.003~ -0.010                                    | 1.20                      | 100                   | ±0.5                      |
| STCA0610N* | DC-6                  | 10               | N3~N10                       | -0.003~ -0.010                                    | 1.20                      | 100                   | ±0.5                      |

**General Specifications**

- Frequency Range DC to 6GHz
- Attenuation 3dB
- Attenuation Accuracy at 25°C ±0.5dB@1GHz
- VSWR 1.20:1 Max. @1GHz at 25°C  
1.20:1 typical @2GHz at 25°C  
1.20:1 typical @3 GHz at 25°C
- Nominal Impedance 50 Ohms
- Power Rating 100 mW CW
- Power Derating 100% @ 125°C  
Derates to 0% @ 150°C
- Operating Temperature -55°C to +150°C
- Temperature Coefficient over Operating Temperature Range: See Table Above.  
Temperature Coefficient Tolerance: ±0.001dB/dB/°C.
- Substrate: Alumina (Al<sub>2</sub>O<sub>3</sub>)
- Resistive material: Thick film
- Terminal material: Thick film, Nickel barrier with pure tin plate (lead free) or with tin (Sn90) plate (10% lead contained)
- Protective Coating: Thick film (ethyl acetate)
- Package Outline: See Sheet 3.
- Workmanship: per MIL-PRF-55342.
- RoHS Compliant.
- Electrostatic Discharge Control: per MIL-STD-1686.

**Unit Marking** dB Value (XX), Direction of Shift (N) and TCA Shift (X).  
Legibility and Permanency: per MIL-STD-130.

**Quality Assurance**

- Sample inspect per ANSI/ASQC Z1.4 general inspection, LEVEL II, AQL = 1.0.
  - 1.1 Visual and mechanical examination for conformance to outline package requirements.
- Select five (5) Units from lot measure attenuation from DC to 6 GHz every 20°C over the temperature range -35°C to +105°C.
  - 2.1 Calculate, using linear regression, the slope of the curve.
  - 2.2 Calculate TCA using the following formula: TCA = Slope / Attenuation @ 25°C.
- Test data required for customer.

**Yantel Corporation**

Add: 3F, Building 3, Southern District 2 of Zhongguan Honghualing Industrial Park, Xili, Nanshan, Shenzhen, China  
Tel: 86-755-8355-1886 Fax: 86-755-8355-2533

For detailed performance specs & shopping online see Yantel web site : [www.yantel-corp.com](http://www.yantel-corp.com)

STCA Response

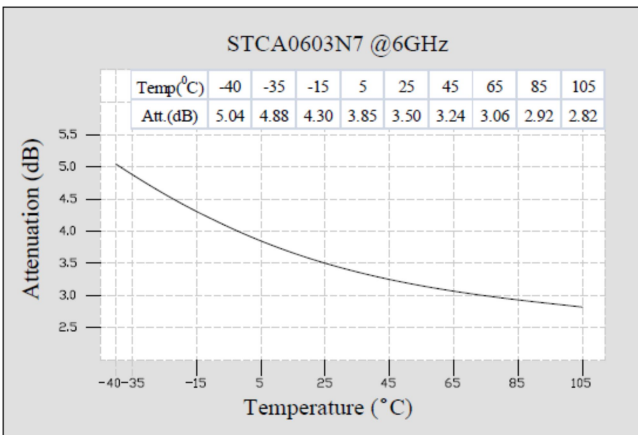
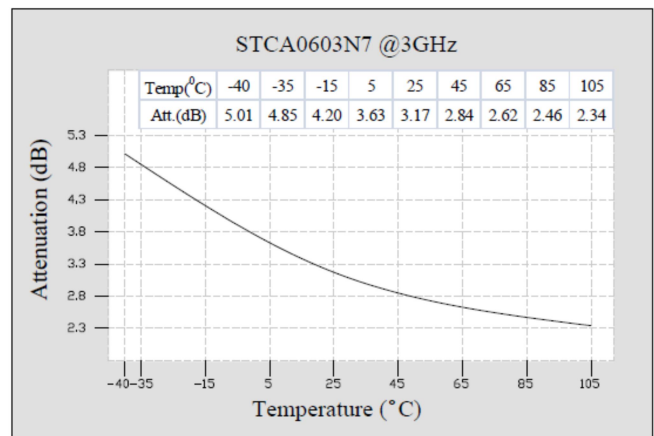
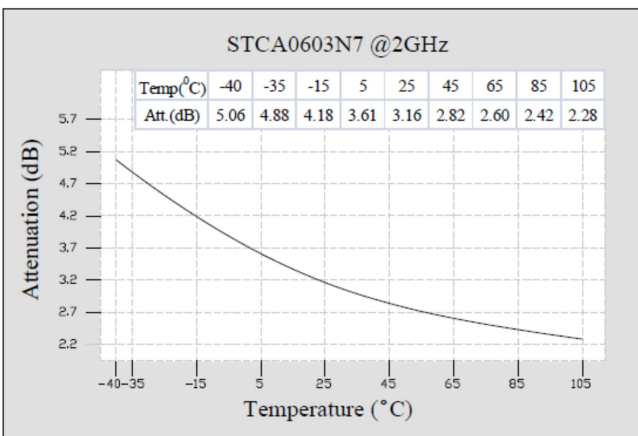
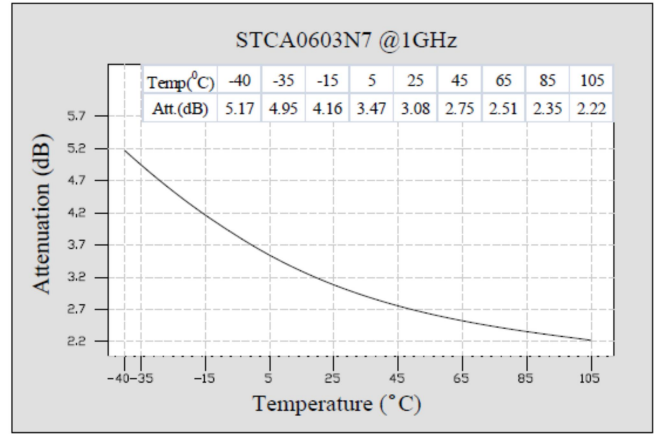
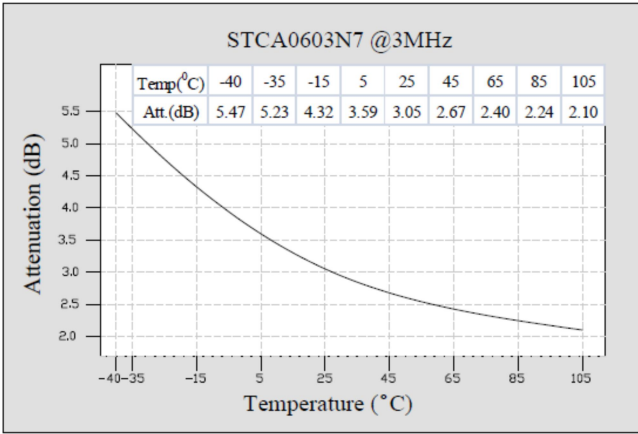

Statistical Table of Attenuation(typ.) VS Temperature

| ATT(dB) \ Temp(°C) | 3MHz | 1GHz | 2GHz | 3GHz |
|--------------------|------|------|------|------|
| -40                | 5.47 | 5.17 | 5.06 | 5.01 |
| -35                | 5.23 | 4.95 | 4.88 | 4.85 |
| -15                | 4.32 | 4.16 | 4.18 | 4.20 |
| 5                  | 3.59 | 3.47 | 3.61 | 3.63 |
| 25                 | 3.05 | 3.08 | 3.16 | 3.17 |
| 45                 | 2.67 | 2.75 | 2.82 | 2.84 |
| 65                 | 2.40 | 2.51 | 2.60 | 2.62 |
| 85                 | 2.24 | 2.35 | 2.42 | 2.46 |
| 105                | 2.10 | 2.22 | 2.28 | 2.34 |

Recommended Layout

All dimensions shown in mm unless stated otherwise

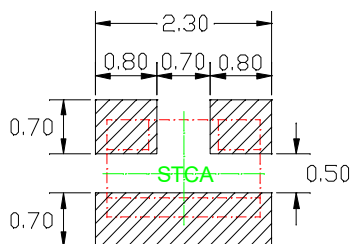

Power Rating & Derating Curve

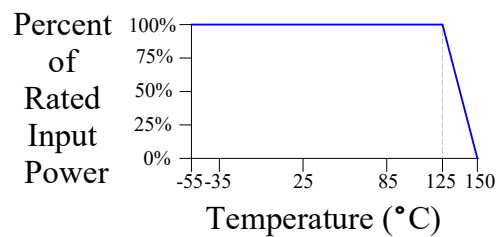

**Package Outlines**

All dimensions shown in mm unless stated otherwise

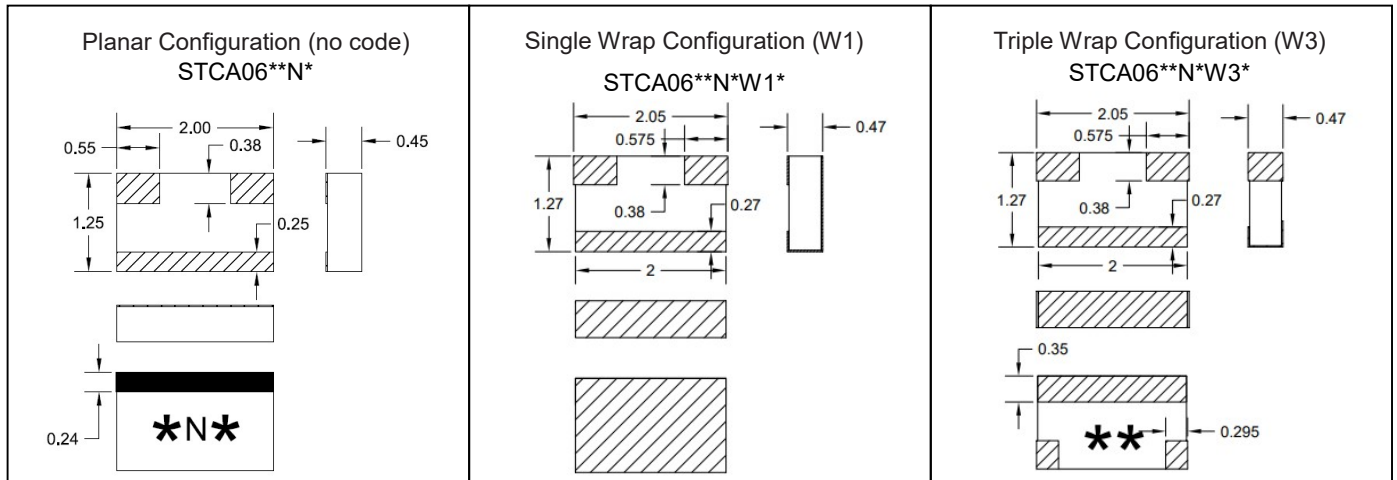
 Note: Dimension tolerance in  $\pm 0.10$  otherwise mention. \* represents number

**Tape & Reel Drawing**

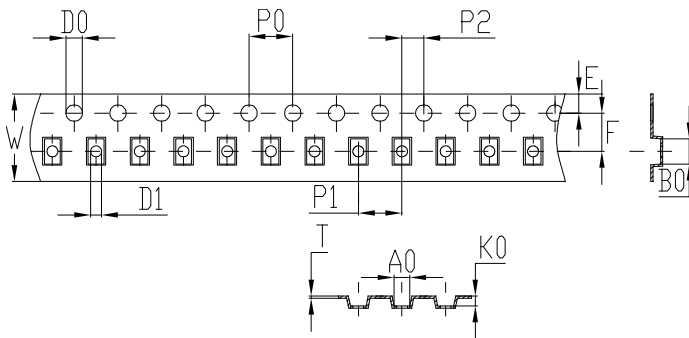
All dimensions shown in mm unless stated otherwise



Notice:

- A. 10 Sprocket hole pitch cumulative tolerance is 0.2mm.
- B. Carrier camber shall be not more than 1mm per 100mm through a length of 250mm.
- C. All dimensions meet EIA-418-B requirements.
- D. A0 & B0 measured as indicated.
- E. K0 measured from a place on the inside bottom of the pocket to top surface of carrier.
- F. Material: PE 100
- G. Thickness:  $0.20 \pm 0.05$ mm
- H. 3000 units (maximum) / T&R

|        |                |                 |                |               |                          |                          |
|--------|----------------|-----------------|----------------|---------------|--------------------------|--------------------------|
| symbol | A0             | B0              | K0             | P0            | P1                       | P2                       |
| spec   | $1.45 \pm 0.1$ | $2.30 \pm 0.1$  | $0.9 \pm 0.1$  | $4.0 \pm 0.1$ | $4.0 \pm 0.1$            | $2.0 \pm 0.1$            |
| symbol | W              | T               | E              | F             | D0                       | D1                       |
| spec   | $8.0 \pm 0.1$  | $0.20 \pm 0.05$ | $1.75 \pm 0.1$ | $3.5 \pm 0.1$ | $\Phi 1.5^{+0.1}_{-0.0}$ | $\Phi 1.0^{+0.1}_{-0.0}$ |

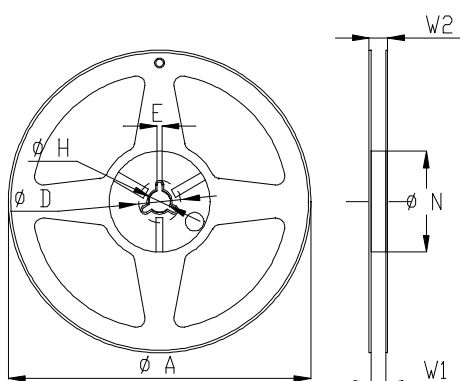

| Symbol | Dimensions(mm) |
|--------|----------------|
| A      | $180^{+0/-3}$  |
| N      | $60^{+1/-0}$   |
| W1     | $9.0 \pm 0.3$  |
| W2     | $11 \pm 1.0$   |
| D      | $25 \pm 0.8$   |
| H      | $13 \pm 0.2$   |
| E      | $3 \pm 0.5$    |

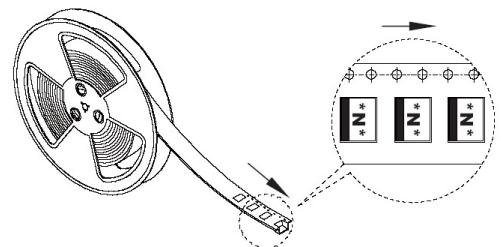

Yantel Corporation

Add: 3F, Building 3, Southern District 2 of Zhongguan Honghualing Industrial Park, Xili, Nanshan, Shenzhen, China

Tel: 86-755-8355-1886 Fax: 86-755-8355-2533

 For detailed performance specs & shopping online see Yantel web site : [www.yantel-corp.com](http://www.yantel-corp.com)