

Temperature Compensation Attenuator DC~6GHz 50Ω 2W 1~10dB N3~N10
Part No. Descriptions

| | | | | | |
|--------|-----------|----------------------------|------------------------------|-------------------------|-------------------------------------|
| *** | ** | ** | ** | ** | * |
| Series | Frequency | Attenuation | Temperature Coefficient Code | Metallization Options | Termination Plating Options |
| | | | | | |
| TCA, | 06 | (01 to 10) 1dB to 10 dB | N3 to N10 | Planar(no code), W1, W3 | (no code)=lead free or (S)=Lead(Pb) |

| Part No. | Frequency Range (GHz) | Attenuation (dB) | Temperature Coefficient Code | Temperature Coefficient of Attenuation (dB/dB/°C) | Max. VSWR (:1) @1GHz@25°C | Max. Input Power (W) | Attenuation Accuracy (dB) |
|-----------|-----------------------|------------------|------------------------------|---|---------------------------|----------------------|---------------------------|
| TCA0601N* | DC-6 | 1 | N3~N9 | -0.003~-0.009 | 1.25 | 2 | ±0.5 |
| TCA0602N* | DC-6 | 2 | N3~N10 | -0.003~-0.010 | 1.25 | 2 | ±0.5 |
| TCA0603N* | DC-6 | 3 | N3~N10 | -0.003~-0.010 | 1.25 | 2 | ±0.5 |
| TCA0604N* | DC-6 | 4 | N3~N10 | -0.003~-0.010 | 1.25 | 2 | ±0.5 |
| TCA0605N* | DC-6 | 5 | N3~N10 | -0.003~-0.010 | 1.25 | 2 | ±0.5 |
| TCA0606N* | DC-6 | 6 | N3~N10 | -0.003~-0.010 | 1.25 | 2 | ±0.5 |
| TCA0607N* | DC-6 | 7 | N3~N10 | -0.003~-0.010 | 1.25 | 2 | ±0.5 |
| TCA0608N* | DC-6 | 8 | N3~N10 | -0.003~-0.010 | 1.25 | 2 | ±0.5 |
| TCA0609N* | DC-6 | 9 | N3~N10 | -0.003~-0.010 | 1.25 | 2 | ±0.5 |
| TCA0610N* | DC-6 | 10 | N3~N10 | -0.003~-0.010 | 1.25 | 2 | ±0.5 |

General Specifications

- Frequency Range DC to 6GHz
- Attenuation 10dB
- Attenuation Accuracy at 25°C ±0.5dB@1GHz
- VSWR 1.25:1 Max. @1GHz, 1.30:1 Max.@2GHz at 25°C
- Nominal Impedance 50 Ohms
- Power Rating 2 Watts CW
- Power Derating 100% @ 125°C
Derates to 0% @ 150°C
- Operating Temperature -55°C to +150°C
- Temperature Coefficient over Operating Temperature Range: See Table Above.
Temperature Coefficient Tolerance: ±0.001dB/dB/°C.
- Substrate: Alumina (Al2O3)
- Resistive material: Thick film
- Terminal material: Thick film, Nickel barrier with pure tin plate (lead free) or with tin (Sn90) plate (10% lead contained)
- Protective Coating: Thick film (ethyl acetate)
- Package Outline: See Sheet 3.
- Workmanship: per MIL-PRF-55342.
- RoHS Compliant.
- Electrostatic Discharge Control: per MIL-STD-1686.

Unit Marking dB Value (XX), Direction of Shift (N) and TCA Shift (X).
Legibility and Permanency: per MIL-STD-130.

Quality Assurance

- Sample inspect per ANSI/ASQC Z1.4 general inspection, LEVEL II, AQL = 1.0.
 - 1.1 Visual and mechanical examination for conformance to outline package requirements.
- Select five (5) Units from lot measure attenuation from DC to 6 GHz every 20°C over the temperature range -35°C to +105°C.
 - 2.1 Calculate, using linear regression, the slope of the curve.
 - 2.2 Calculate TCA using the following formula: TCA = Slope / Attenuation @ 25°C.
- Test data required for customer.

Yantel Corporation

Add: 3F, Building 3, Southern District 2 of Zhongguan Honghualing Industrial Park, Xili, Nanshan, Shenzhen, China
Tel: 86-755-8355-1886 Fax: 86-755-8355-2533

For detailed performance specs & shopping online see Yantel web site : www.yantel-corp.com

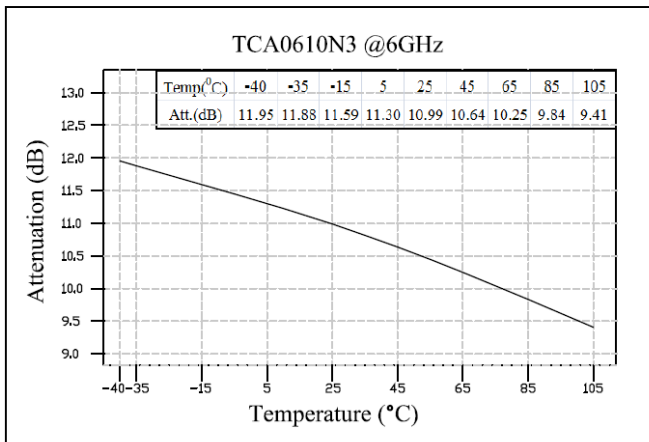
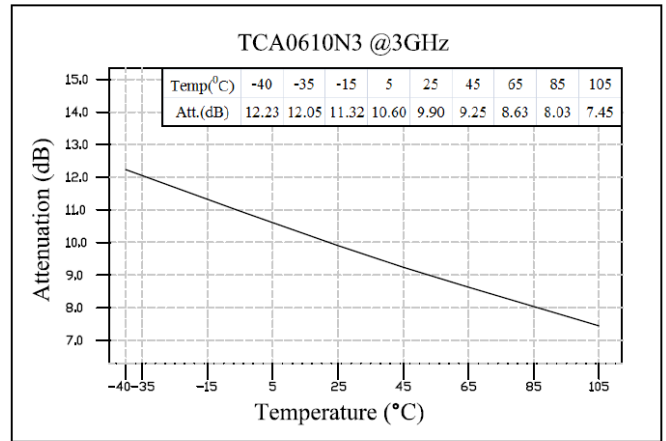
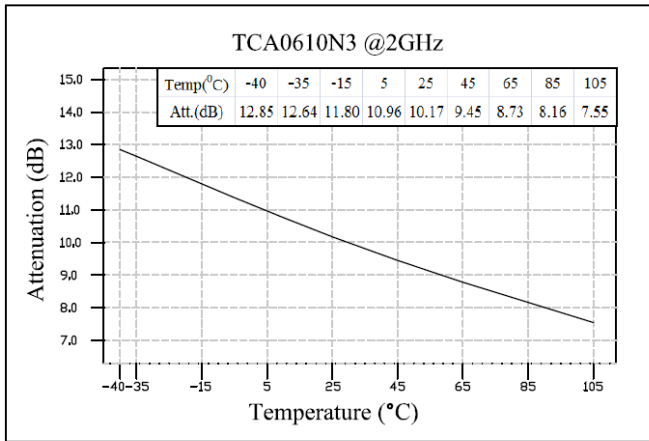
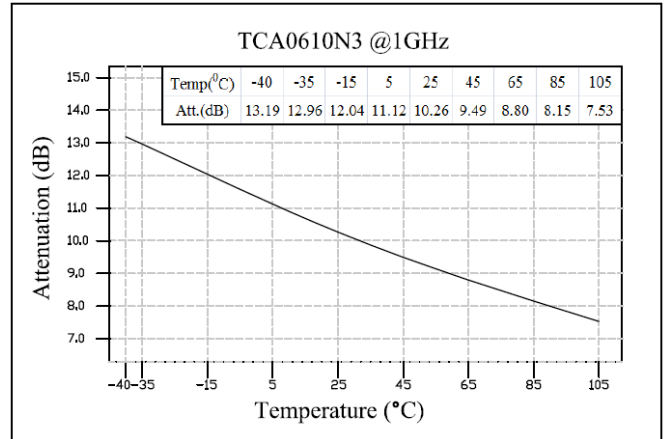
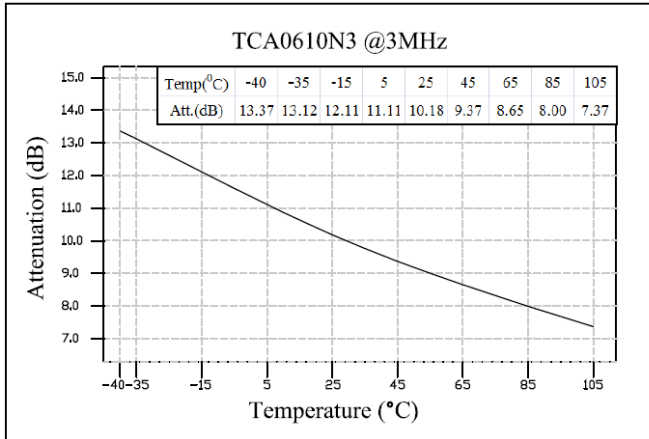
TCA Response

| Temp(°C) \ ATT(dB) | 3MHz | 1GHz | 2GHz | 3GHz |
|--------------------|-------|-------|-------|-------|
| -40 | 13.37 | 13.19 | 12.85 | 12.23 |
| -35 | 13.12 | 12.96 | 12.64 | 12.05 |
| -15 | 12.11 | 12.04 | 11.80 | 11.32 |
| 5 | 11.11 | 11.12 | 10.95 | 10.60 |
| 25 | 10.18 | 10.26 | 10.17 | 9.90 |
| 45 | 9.37 | 9.49 | 9.45 | 9.25 |
| 65 | 8.65 | 8.80 | 8.73 | 8.63 |
| 85 | 8.00 | 8.15 | 8.16 | 8.03 |
| 105 | 7.37 | 7.53 | 7.55 | 7.45 |

Recommended Layout

All dimensions shown in mm unless stated otherwise

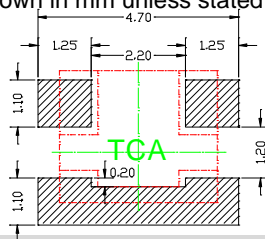
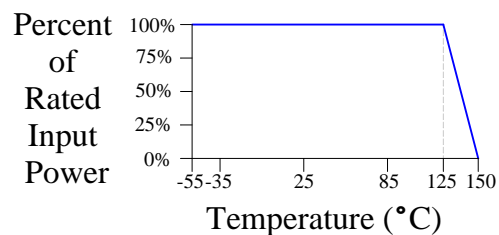
Power Rating & Derating Curve

Yantel Corporation

Add: 3F, Building 3, Southern District 2 of Zhongguan Honghualing Industrial Park, Xili, Nanshan, Shenzhen, China

Tel: 86-755-8355-1886 Fax: 86-755-8355-2533

 For detailed performance specs & shopping online see Yantel web site : www.yantel-corp.com

Package Outlines

All dimensions shown in mm unless stated otherwise

Note: Dimension tolerance in ± 0.10 otherwise mention. * represents number

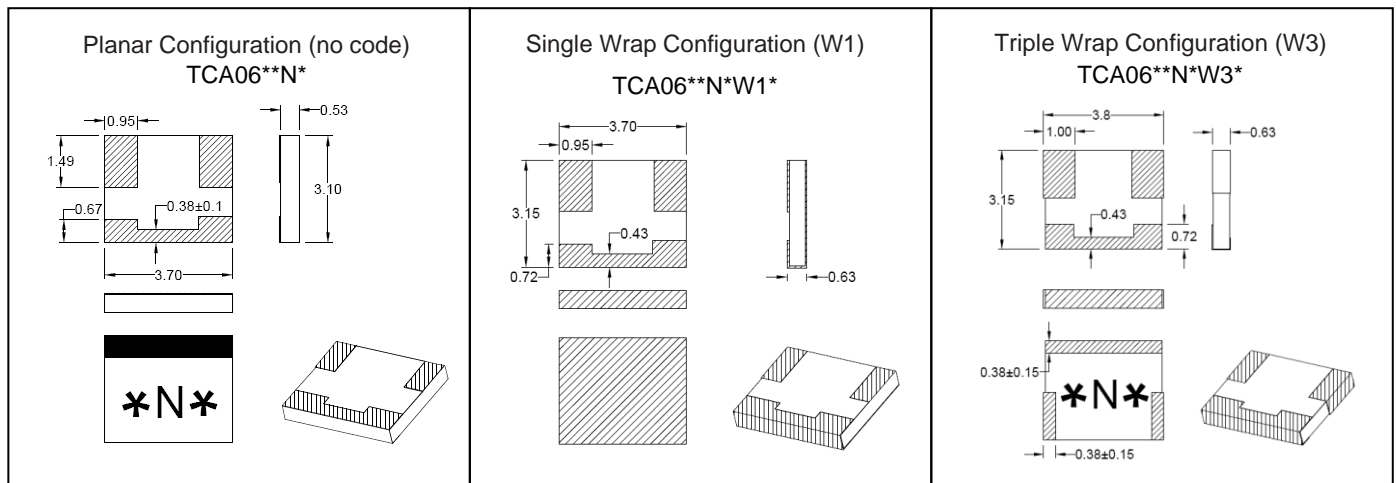

Tape & Reel Drawing

All dimensions shown in mm unless stated otherwise

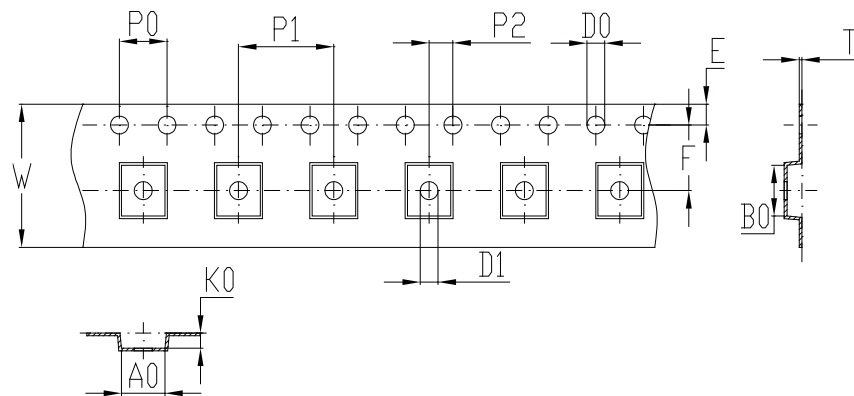

Notice:

- A.10 Sprocket hole pitch cumulative tolerance is 0.2mm.
- B. Carrier camber shall be not more than 1mm per 100mm through a length of 250mm.
- C. All dimensions meet EIA-418-B requirements.
- D. A0 & B0 measured as indicated.
- E. K0 measured from a place on the inside bottom of the pocket to top surface of carrier.
- F. Material: PE 100
- G. Thickness: 0.23 ± 0.05 mm
- H. 1500 units (maximum) / T&R

| | | | | | | |
|--------|----------------|-----------------|----------------|---------------|--------------------------|----------------|
| symbol | A0 | B0 | K0 | P0 | P1 | P2 |
| spec | 3.65 ± 0.1 | 4.25 ± 0.1 | 1.25 ± 0.1 | 4.0 ± 0.1 | 8.0 ± 0.1 | 2.0 ± 0.1 |
| symbol | W | T | E | F | D0 | D1 |
| spec | 12.0 ± 0.3 | 0.23 ± 0.05 | 1.75 ± 0.1 | 5.5 ± 0.1 | $\Phi 1.5^{+0.1}_{-0.0}$ | $\Phi 1.5$ min |

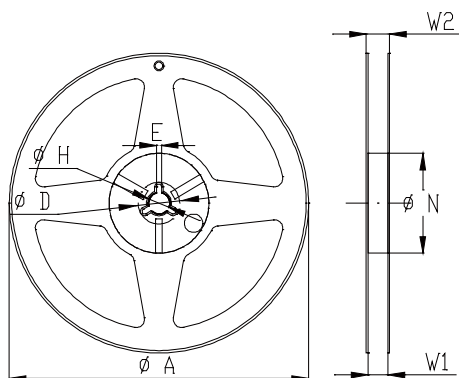

| Symbol | Dimensions(mm) |
|--------|----------------|
| A | $180^{+0/-3}$ |
| N | $60^{+1/-0}$ |
| W1 | 12.0 ± 0.3 |
| W2 | 14 ± 1.0 |
| D | 25 ± 0.8 |
| H | 13 ± 0.2 |
| E | 3 ± 0.5 |

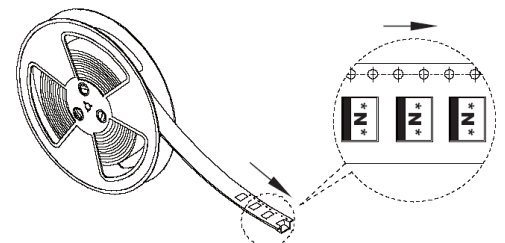

Yantel Corporation

Add: 3F, Building 3, Southern District 2 of Zhongguan Honghualing Industrial Park, Xili, Nanshan, Shenzhen, China

Tel: 86-755-8355-1886 Fax: 86-755-8355-2533

For detailed performance specs & shopping online see Yantel web site : www.yantel-corp.com