

Part No. Description

TCA ** ** **

Frequency Attenuation Temperature coefficient code

Model	Frequency Range (GHz)	Attenuation (dB)	Temperature Coefficient Code	Temperature Coefficient of Attenuation (dB/dB/°C)	Max. VSWR (:1) @1GHz@25°C	Max. Input Power (W)	Attenuation Accuracy (dB)
TCA0601N*	DC-6	1	N3~N9	-0.003~ -0.009	1.2	2	±0.3
TCA0602N*	DC-6	2	N3~N9	-0.003~ -0.009	1.2	2	±0.3
TCA0603N*	DC-6	3	N3~N9	-0.003~ -0.009	1.2	2	±0.3
TCA0604N*	DC-6	4	N3~N9	-0.003~ -0.009	1.2	2	±0.5
TCA0605N*	DC-6	5	N3~N9	-0.003~ -0.009	1.2	2	±0.5
TCA0606N*	DC-6	6	N3~N9	-0.003~ -0.009	1.2	2	±0.5
TCA0607N*	DC-6	7	N3~N9	-0.003~ -0.009	1.2	2	±0.5
TCA0608N*	DC-6	8	N3~N9	-0.003~ -0.009	1.2	2	±0.5
TCA0609N*	DC-6	9	N3~N9	-0.003~ -0.009	1.2	2	±0.5
TCA0610N*	DC-6	10	N3~N9	-0.003~ -0.009	1.2	2	±0.5

Specifications

1. Frequency Range DC to 6GHz
2. Attenuation 10dB
3. Attenuation Accuracy at 25°C ±0.5dB@1GHz
4. VSWR 1.2:1 Max. @1GHz at 25°C
5. Nominal Impedance 50 Ohms
6. Power Rating 2 Watts
7. Power Derating 100% @ 25°C
Derates to 0% @ 150°C
8. Operating Temperature -55°C~+150°C
9. Temperature Coefficient Over Operating Temperature Range: See Table Above ,
Temperature coefficient Tolerance:+0.001dB/dB/°C
10. RoHS Compliant Lead Free Silver Over Nickel Plating
11. Electrostatic Discharge Control: PER MIL-STD-1686

Unit Marking dB Value (XX), Direction of Shift (N) and TCA Shift(X)
 Legibility and Permanency Per MIL-STD-130

Quality Assurance

1. Sample Inspect PER ANSI/ASQC Z1.4 General Inspection, LEVEL II, AQL = 1.0
2. Select five (5) Units from lot measure DCA every 20°C Over The temperature range -55°C TO +125°C
 - 2.1 Calculate, using linear regression, The slope of the curve.
 - 2.2 Calculate TCA using the following formula: TCA = Slope / Attenuation @ 25°C
3. Inspection in accordance with QA00006 and FORM0357 for commercial grade product
4. TEST DATA required for customer

Package: Standard pack per MC0023

Yantel Corporation

Add:2nd Floor,Building 2,Gaofa Technology Park,Longjing,Nanshan,Shenzhen,China.PC 518055

Tel: 86-755-8355-1886 Fax: 86-755-8355-2533

For detailed performance specs & shopping online see Yantel web site : www.yantel-corp.com

TCA Response

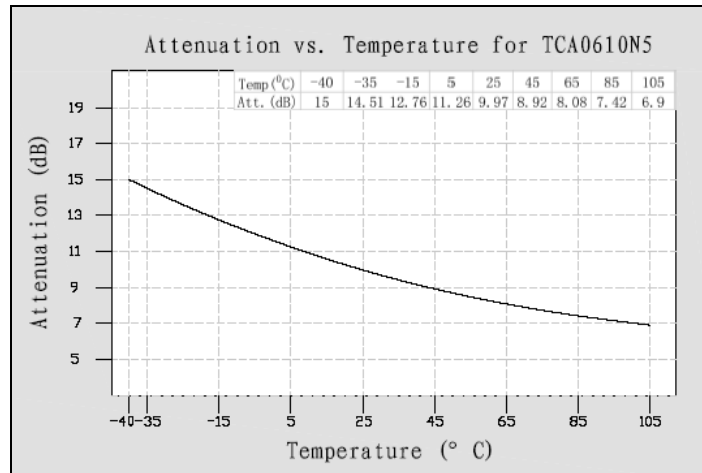

Package Outlines

All dimensions shown in mm unless stated otherwise

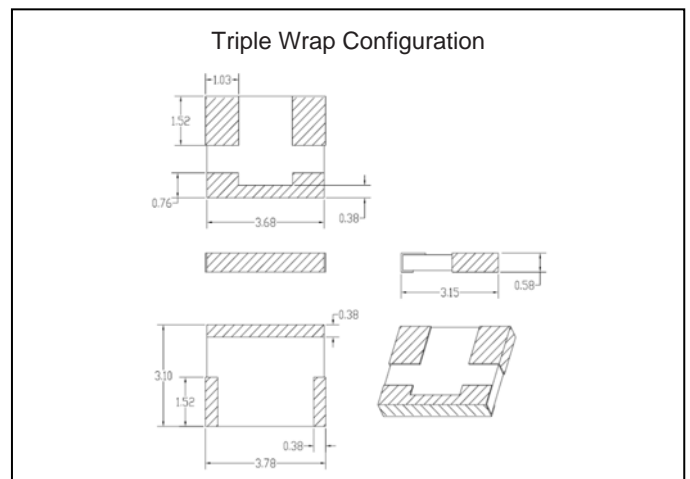
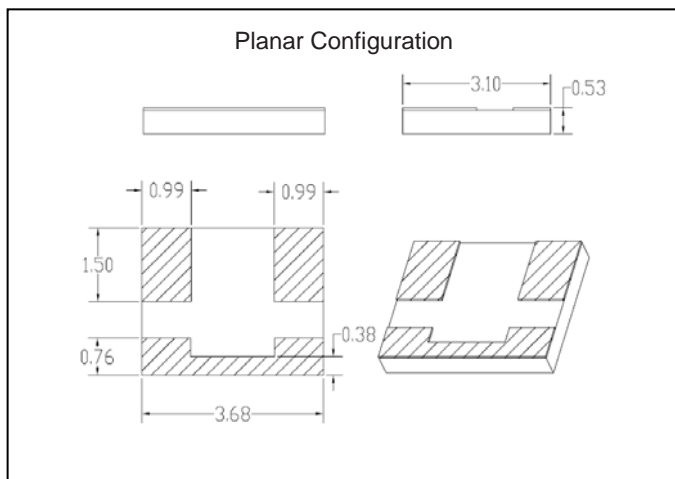

Tape&Reel

All dimensions shown in mm unless stated otherwise

