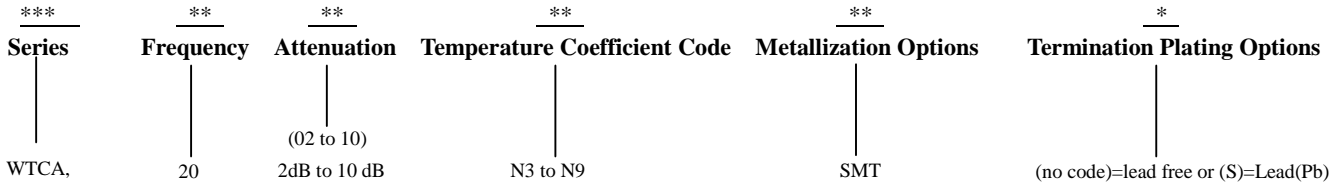
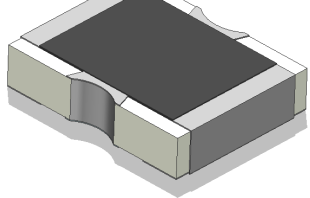

Part No. Descriptions

Part No.	Frequency Range (GHz)	Attenuation (dB)	Temperature Coefficient Code	Temperature Coefficient of Attenuation (dB/dB/°C)	Max. VSWR (:1) @1GHz@25°C	Max. Input Power (mW)	Attenuation Accuracy (dB)
WTCA2002N*SMT	DC-20	2	N3~N9	-0.003~ -0.09	1.2	200	±0.5
WTCA2003N*SMT	DC-20	3	N3~N9	-0.003~ -0.09	1.2	200	±0.5
WTCA2004N*SMT	DC-20	4	N3~N9	-0.003~ -0.09	1.2	200	±0.5
WTCA2005N*SMT	DC-20	5	N3~N9	-0.003~ -0.09	1.2	200	±0.5
WTCA2006N*SMT	DC-20	6	N3~N9	-0.003~ -0.09	1.2	200	±0.5
WTCA2007N*SMT	DC-20	7	N3~N9	-0.003~ -0.09	1.2	200	±0.5
WTCA2008N*SMT	DC-20	8	N3~N9	-0.003~ -0.09	1.2	200	±0.5
WTCA2009N*SMT	DC-20	9	N3~N9	-0.003~ -0.09	1.2	200	±0.5
WTCA20010N*SMT	DC-20	10	N3~N9	-0.003~ -0.09	1.2	200	±0.5

General Specifications

- | | | |
|---|---|--|
| <ol style="list-style-type: none"> 1. Frequency Range 2. Attenuation 3. Attenuation Accuracy 4. VSWR 5. Nominal Impedance 6. Power Rating 7. Power Derating 8. Operating Temperature 9. Temperature Coefficient over Operating Temperature Range: See Table Above. 10. Substrate: Alumina (Al₂O₃) 11. Resistive material: Thick film 12. Terminal material: Thick film, Nickel barrier with pure tin plate (lead free) or with tin (Sn90) plate (10% lead contained) 13. Protective Coating: Thick film (ethyl acetate) 14. Package Outline: See Sheet 4. 15. Workmanship: per MIL-PRF-55342. 16. RoHS Compliant. 17. Electrostatic Discharge Control: per MIL-STD-1686. | <p>DC to 20GHz
6dB
at 25°C ±0.5dB@1GHz
at 25°C 1.55:1 Max. over DC - 9GHz
1.45:1 Max. over 9 - 20GHz</p> <p>50 Ohms
200 mW CW
100% @ 125°C
Derates to 0% @ 150°C</p> <p>-55°C to +150°C</p> <p>Temperature Coefficient Tolerance: ±0.001dB/dB/°C.</p> |  |
|---|---|--|

Unit Marking dB Value (XX), Direction of Shift (N) and TCA Shift (X).
Legibility and Permanency: per MIL-STD-130.

Quality Assurance

1. Sample inspect per ANSI/ASQC Z1.4 general inspection, LEVEL II, AQL = 1.0.
 - 1.1 Visual and mechanical examination for conformance to outline package requirements.
2. Select five (5) Units from lot measure attenuation from DC to 20GHz every 20°C over the temperature range -55°C to +125°C.
 - 2.1 Calculate, using linear regression, the slope of the curve.
 - 2.2 Calculate TCA using the following formula: TCA = Slope / Attenuation @ 25°C.
3. Test data required for customer.

Yantel Corporation

Add: 3F, Building 3, Southern District 2 of Zhongguan Honghualing Industrial Park, Xili, Nanshan, Shenzhen, China

Tel: 86-755-8355-1886 Fax: 86-755-8355-2533

 For detailed performance specs & shopping online see Yantel web site : www.yantel-corp.com

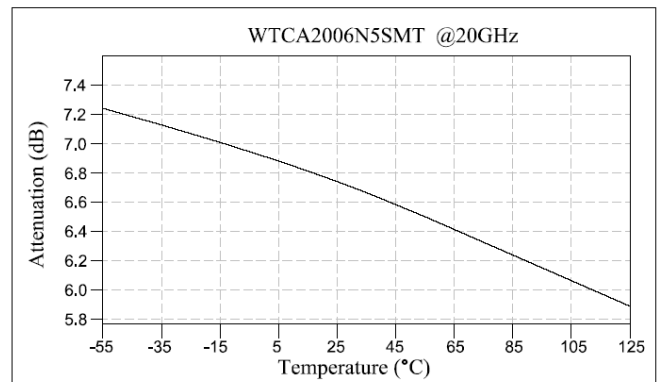
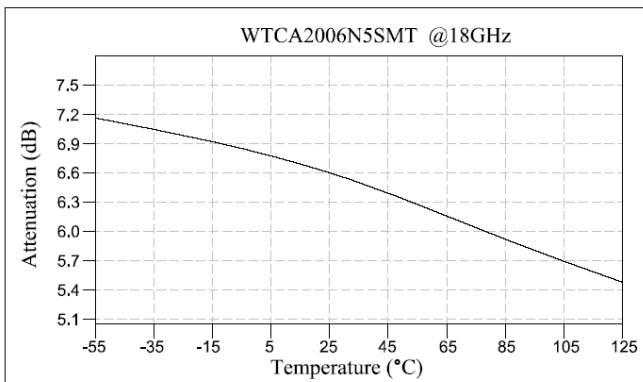
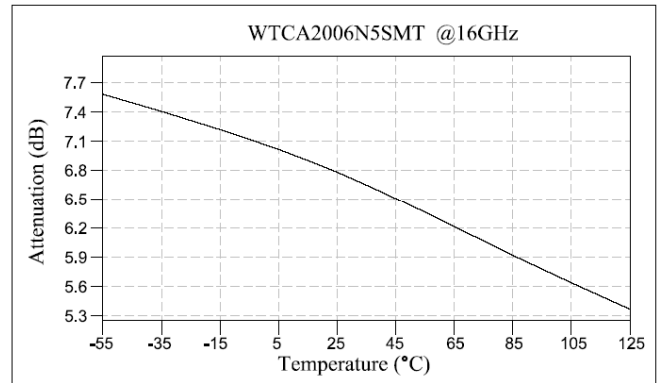
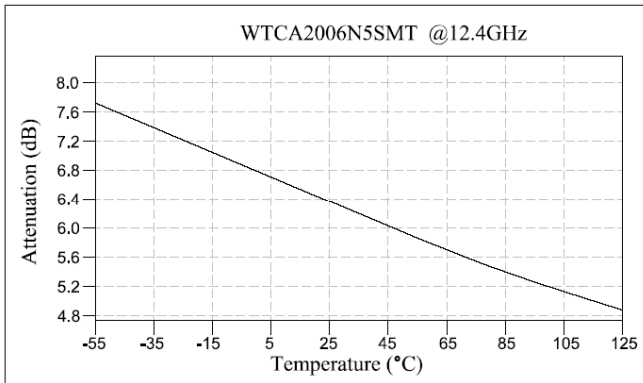
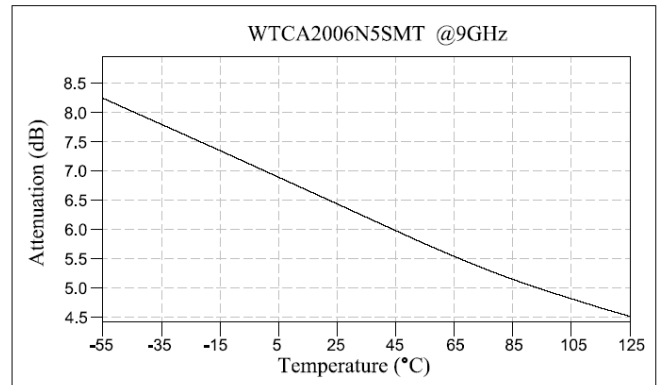
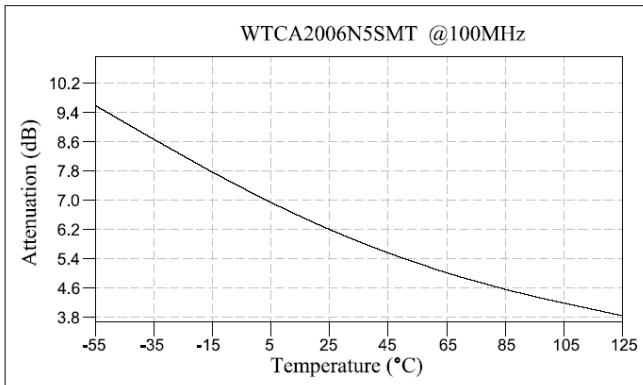
WTCA Response

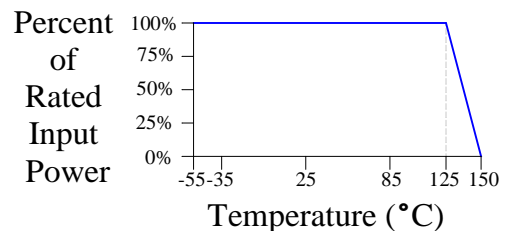
Typical VSWR @25°C

Power Rating & Derating Curve

Notes on RF Testing and Circuit Layout

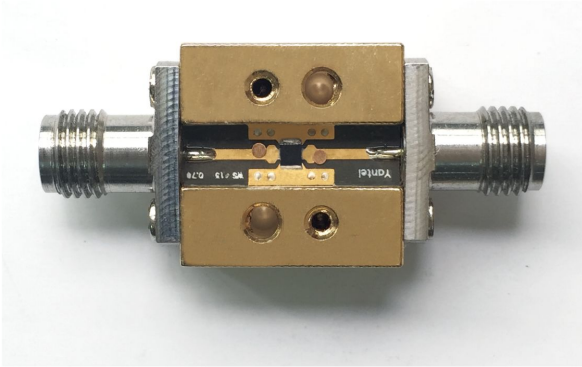
DC-20GHz SMT series(for SMT type) Test Fixture



SMT PCB Test Board

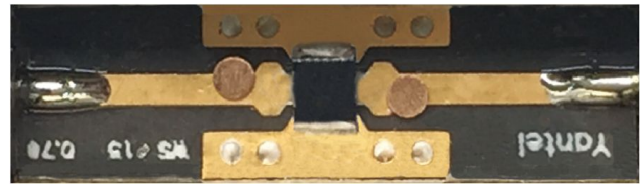

Connect test part to Test Fixture

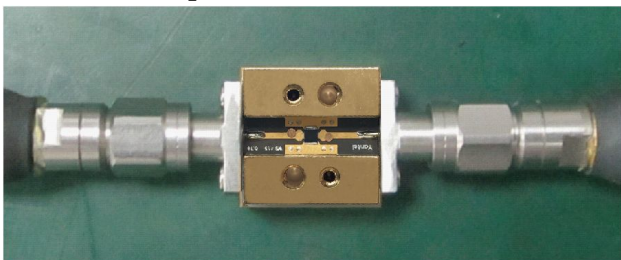

Equipment Calibration



**Room
Temperature
Test**

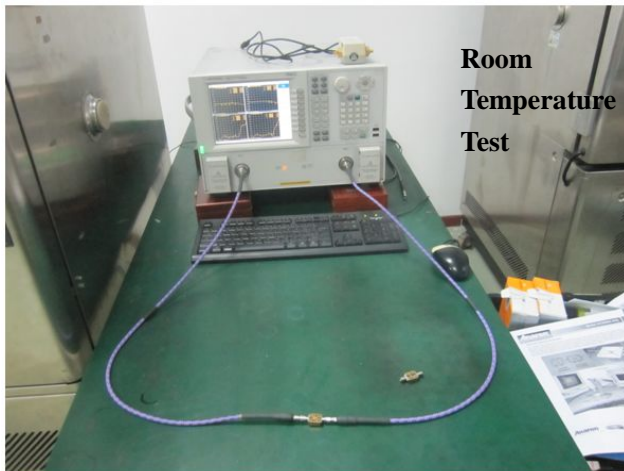

**High-Low
Temperature
Test**

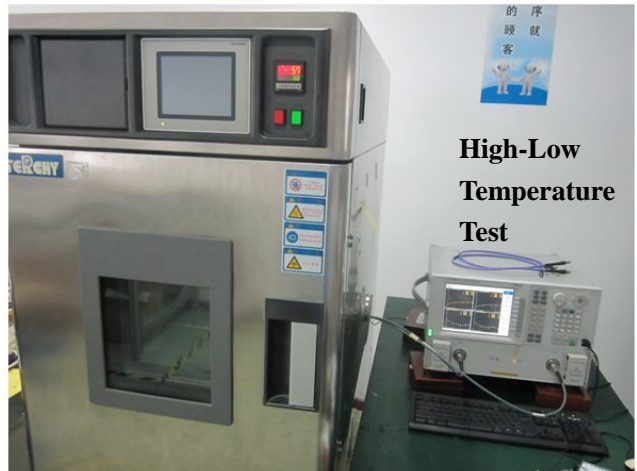

- 1、 S2P documents are available for download
- 2、 DC-20GHz or 16-36GHz test fixture is rentable (only for Chinese customers) , otherwise please purchase them.

For any questions or needs, please feel free to contact inform@yantel-corp.com.

Package Outlines

All dimensions shown in mm unless stated otherwise
 Note: Dimension tolerance in ± 0.10 otherwise mention.

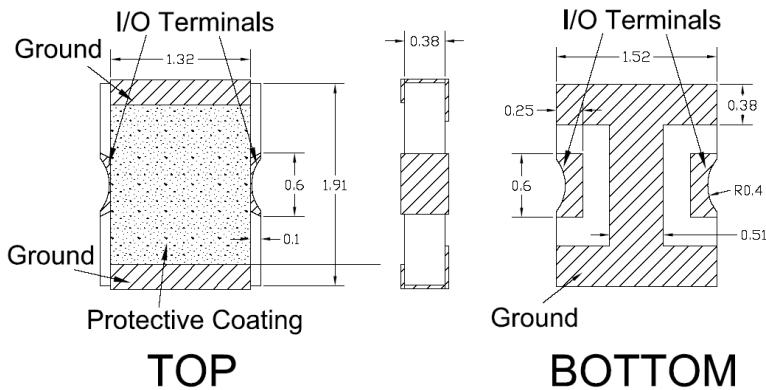

Recommended PCB Layout

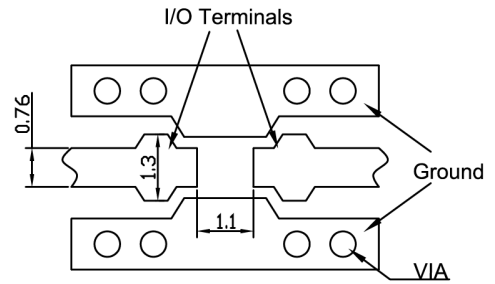

NOTE:

1. 50Ω line width is shown above designing from Rogers5880 dielectric thickness 0.254mm; copper H OZ
2. Bottom side of the PCB is continuous ground plane.
3. All dimensions shown in mm.

Tape & Reel Drawing

All dimensions shown in mm unless stated otherwise

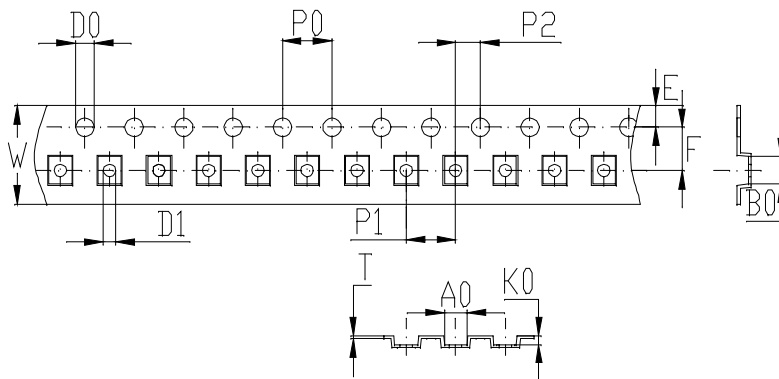

Notice:

- A.10 Sprocket hole pitch cumulative tolerance is 0.2mm.
- B. Carrier camber shall be not more than 1mm per 100mm through a length of 250mm.
- C. All dimensions meet EIA-418-B requirements.
- D. A0 & B0 measured as indicated.
- E. K0 measured from a place on the inside bottom of the pocket to top surface of carrier.
- F. Material: PS
- G. Thickness: 0.25 ± 0.05 mm
- H. 3000 units (maximum) / T&R

symbol	A0	B0	K0	P0	P1	P2
spec	1.85 ± 0.1	2.25 ± 0.1	0.7 ± 0.1	4.0 ± 0.1	4.0 ± 0.1	2.0 ± 0.1
symbol	W	T	E	F	D0	D1
spec	8.0 ± 0.3	0.25 ± 0.05	1.75 ± 0.1	3.5 ± 0.1	$\Phi 1.5^{+0.1}_{-0.0}$	$\Phi 1.0^{+0.1}_{-0.0}$

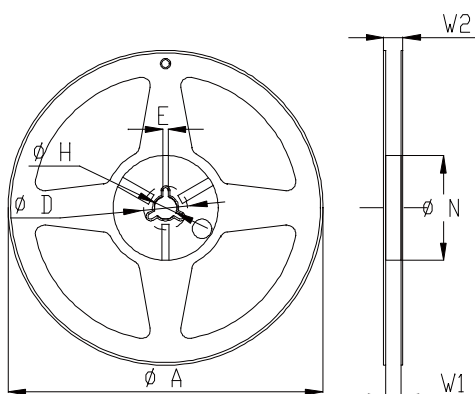

Symbol	Dimensions(mm)
A	180+0/-3
N	60+1/-0
W1	9.0±0.3
W2	11±1.0
D	25±0.8
H	13±0.2
E	3±0.5

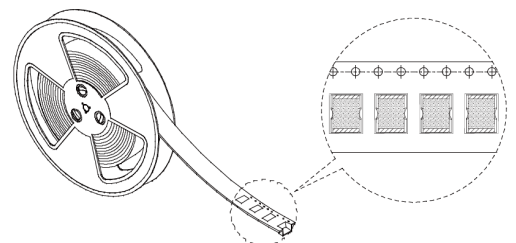

Yantel Corporation

Add: 3F, Building 3, Southern District 2 of Zhongguan Honghualing Industrial Park, Xili, Nanshan, Shenzhen, China

Tel: 86-755-8355-1886 Fax: 86-755-8355-2533

For detailed performance specs & shopping online see Yantel web site : www.yantel-corp.com